

SPECIFICATION CV461/2/3
ISSUE 3 DATED 25.11.52

AMENDMENT NO. 1

PAGE 1 RATING

Amend Max. Transmitter Peak Power to read 50KW NOTE B

ADD: NOTE B: Higher power levels up to 200KW may be used, but this will result in a shorter life period of less than 200 hours.

JULY 1961

ROYAL RADAR ESTABLISHMENT

CV 461
 CV 462
 CV 463

MINISTRY OF SUPPLY - DLRD(A)/TRE

VALVE ELECTRONIC

Specification MOS(A)/CV461 Specification MOS(A)/CV462 Specification MOS(A)/CV463 Issue 3 Dated 25.11.52 To be read in conjunction with K1001, excluding clauses 5.2 and 5.8.	<u>SECURITY</u>	
	<u>Specification</u>	<u>Valve</u>
	UNCLASSIFIED	UNCLASSIFIED

—————▶ Indicates a change

TYPE OF VALVE - Broad-band TB Cell PROTOTYPE - VX4088; VX4089; VX4090		<u>MARKING</u>
		See K1001/4
<u>RATING</u>		<u>DIMENSIONS</u>
		See Drawing on Page 4
	Note	
Min. Transmitter Peak Power (kW)	5	
Max. Transmitter Peak Power (kW)	200	
Frequency Coverage - CV461 (Mcs)	9315 to 9435	
- CV462	(Mcs) 9180 to 9300	
- CV463	(Mcs) 9020 to 9140	
<u>NOTE</u>		
A. At least one washer of the dimensions shown in the Drawing on Page 4, shall be supplied with each valve.		

CV 461
CV 462
CV 463

TESTS

To be performed in addition to those applicable in K1001

	Test Conditions	Test	Limits		No. Tested	Note
			Min.	Max.		
a	Valve shall be mounted as shown in Drawing on Page 5 and terminated in a matched load. Test Frequency (Fo) CV461 = 9375 Mcs \pm 0.05% CV462 = 9240 Mcs \pm 0.05% CV463 = 9080 Mcs \pm 0.05%	Tuning Susceptance	-0.06	+0.06	100%	1 2,4.
b	As for Test (a)	Equivalent Conductance	-	0.1	100%	2
c	Valve shall be mounted as shown in Drawing on Page 5 and terminated in a matched load. Line to be energised with 4kW peak RF. Frequency = 9240 Mcs \pm 1.5% Tp = 1 usec \pm 10% PRF = 1000 pps \pm 10% Test to be performed at least 7 days after pumping and not less than 24 hours after any previous discharge.	Firing Time (secs) i.e. Time interval between application of power and tube firing	-	10	100%	
d	As for Test (c)	Arc Loss (db)	-	0.8	100%	3
e	As for Test (c), except that the line shall be energised with 12 to 15 kW peak RF derived from a higher power source through an attenuator of at least 6 db. Frequency = 9240 Mcs \pm 1.5% Tp = 1 usec \pm 10% PRF = 1000 pps \pm 10%	Recovery Loss (db) Measured by a signal generator pulse injected 2 usecs after trailing edge of the transmitter pulse. Signal generator frequency: CV461 = 9375Mcs \pm 0.05% CV462 = 9240Mcs \pm 0.05% CV463 = 9080Mcs \pm 0.05%	-	2.0	100%	
f	As for Test (a)	Loaded Q	-	6.5	TA	4

TESTS (Cont'd)

	Test Conditions	Test	Limits		No. Tested	Note
			Min.	Max.		
g	As for Test (e) Load Standing Wave Ratio to be less than 1.03:1	High-level Standing Wave Ratio CV461 CV462 CV463	0.91 0.91 0.87	- - -	8	5

NOTES

1. The susceptance may be measured by comparing the phase of the reflection with that of a valve which is resonant at the test frequency. The susceptance is given by:-

$$\frac{B}{Y_0} = \frac{(1 + 2 G/Y_0)}{2} \tan \frac{4\pi\Delta l}{\lambda g} \approx (1.1) \frac{2\pi\Delta l}{\lambda g} \text{ for small } \Delta l$$

Where λg is the guide wavelength and Δl is the phase shift measured in the same units as λg and where G/Y_0 is assumed to be 0.05.

2. A curve of SWR vs Frequency is plotted around a centre value of Test Frequency (F_0). See Test Clause (a). The valve is resonant ($B = 0$) at the frequency corresponding to the maximum SWR. The value of SWR is:-

$$S = \frac{1}{G/Y_0} + 1 \quad \text{therefore } G/Y_0 = \frac{1}{S-1}$$

If the valve has passed the susceptance test ($B < 0.06 Y_0$), the SWR measured at Test Frequency (F_0) is very nearly equal to $\frac{1}{G/Y_0} + 1$ and may be used to measure G .

3. The power loss in the arc shall be less than 680 W peak:-

$$\frac{P}{P - P_L} = \frac{4000}{4000 - 680} = 1.20 \text{ (0.8db)}$$

4. Loaded Q is defined as:-

$$Q_L = \frac{F_0 \frac{dB/Y_0}{dF}}{2(1 + G/Y_0)} \quad \text{where } F_0 = \text{Test Frequency. See Test Clause (a).}$$

5. This test may be made at low levels, simulating the arc by a metallic short in intimate contact with the inside of the window.

DIMENSIONS OF CV 461, CV462 & CV 463.

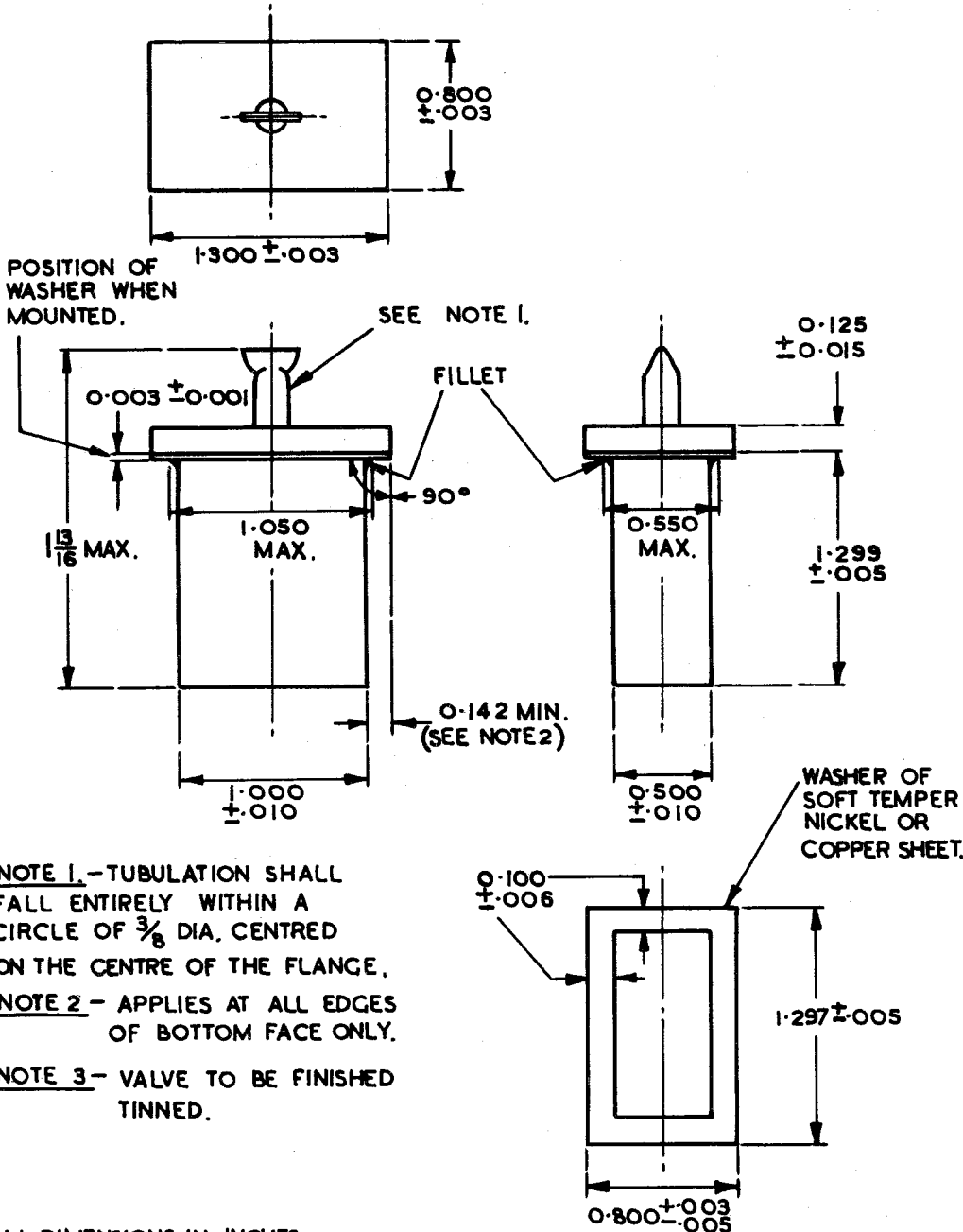

ALL DIMENSIONS IN INCHES.

MOUNT FOR TESTING CV461, CV462 AND CV463.

NOTE 1. 0.015 CUT-AWAY AT SIDE OF WAVEGUIDE MEASURED FROM THE PLANE OF THE INNER SURFACE OF THE TOP OF THE WAVEGUIDE.

NOTE 2 0.030 TO 0.040 SPACING ALL ROUND THE VALVE.

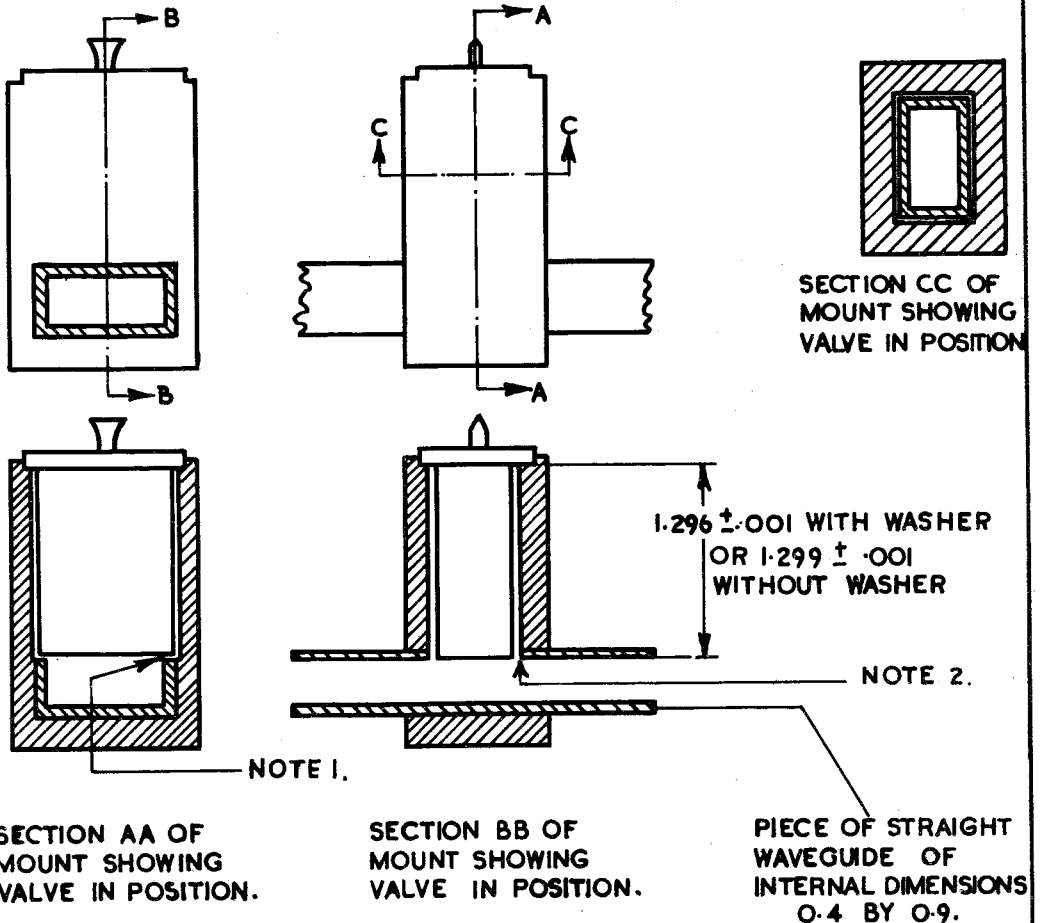

ALL DIMENSIONS IN INCHES